



Isolators

The ins and outs of isolation: a guide to selecting the right isolator

Acromag manufactures a variety of Flat Pack isolators to provide a cost-effective solution for many applications. The primary function of the isolator is to eliminate ground loops that may exist between two or more instruments. A classical application isolates the control room equipment (computers, PLC, DCS etc.) from field devices which may have different ground potentials. In addition to breaking up ground loops, the isolators protect control room equipment from damaging transient spikes and noise generated in the field. Choosing the proper and most cost-effective isolator requires an understanding of the application and consideration of future expansion requirements.

Flat Pack isolators are available in 2-, 3-, and 4-wire configurations. Isolators are further classified as input, output, or 3-way (input, output, power) isolators. Input isolation implies the input signal has no electrical connection to the output and power signals. Output isolation implies the output signal has no connection to the input and power. And similarly, 3-way isolation refers to a situation where there is no electrical path between the input, output, or power.

This article describes four types of isolators and typical PLC/DCS applications in which they are best suited. Each isolator produces a 4-20mA DC output signal corresponding to the 4-20mA DC input signal.



Acromag's compact, DIN rail-mount isolators are available in AC-, DC-, and loop-powered models.

3-Way Isolators

First, we'll discuss Acromag's 611T, 330i, and 430i isolators which provide 3-way (input, output, and power) isolation. They are the safest choice when retrofitting or expanding an existing system. They provide complete isolation when uncertainties about the isolation of instruments in each current loop exist or the grounding scheme is unknown.

The 611T and 330i are DC-powered isolators that operate from an unregulated power supply of 10 to 36V DC. The 430i is AC-powered and uses either 115V AC or 230V AC. The input loop burden of these isolators is less than 1.5V DC at 20mA or approximately 75 ohms.

These 3-way isolators source current out and do not utilize a separate output power supply. It is important to note that the outputs of these isolators are designed to drive purely resistive loads.

Figure 1 shows a typical application for a 3-way isolator. The primary difference between the 611T/330i and 430i models is the power source.

The isolator can be several or hundreds of feet away from the PLC/DCS and obtains power from an external AC or DC source. This source may have a different ground potential than the PLC/DCS or field device. If this is the case, the power ground must be isolated from both the input and output. In this example, the isolator input is monitoring a grounded field sensor at a remote site 300ft. away. The ground potential at the sensor is likely to be different from the power source and PLC/DCS. Consequently, input to output isolation is also necessary.

Additionally, it is important to note that the 611T, 330i, and 430i can isolate 4-20mA control outputs from the PLC/DCS to field actuators. The PLC/DCS analog outputs are wired to the isolator input and the isolator outputs are wired to the field device/actuator. Although 3-way isolation is the safest and most flexible, it is also the most expensive due to the power isolation circuitry.

Figure 1: Long lead lengths, multiple grounds, separate power supply, 3-way isolation required.

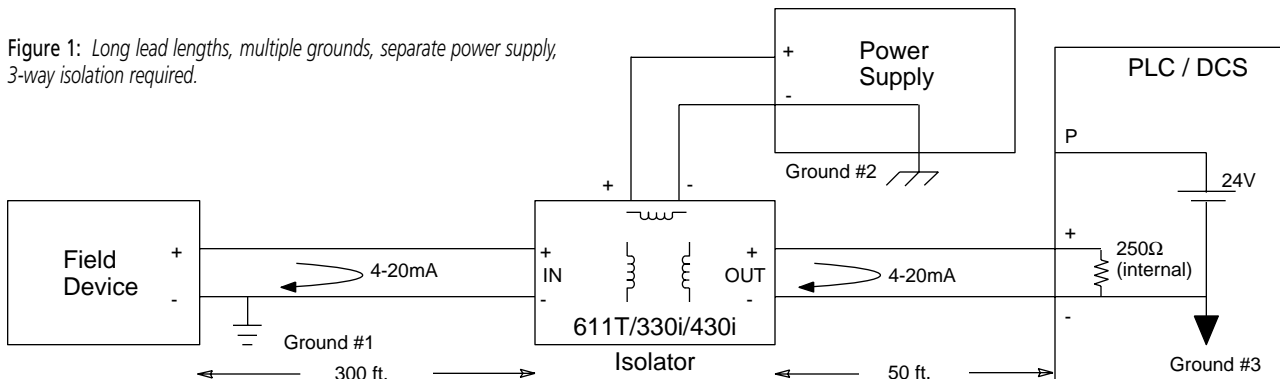



Input Isolators

Suppose we relocate the isolators close to the PLC/DCS. The output and power can now share a common grounding point with the PLC/DCS, and 3-way isolation is no longer necessary. But since the input wiring remains the same (see Figure 2), input isolation is still required. A very cost-effective solution is the Acromag 340i input isolator which provides 250V AC of continuous isolation from input to output/power. Eliminating the power isolation circuitry saves as much as \$95 per isolated point.

The 340i is ideal for applications requiring multiple isolators at a single location where all isolators share the same power supply. PLCs and DCSs usually have 24V DC power available at their input terminals. This is ideal for the 340i which operates over an unregulated power supply range of 10 to 36V DC.

Since the 340i is an input isolator, its 4-20mA output signal and DC power share a common lead. This common lead should be wired directly back to the PLC/DCS's internal ground. Avoid the urge to daisy-chain the common leads

between multiple isolators and run a single wire back to the PLC/DCS. Each isolator should have its own ground path back to the monitoring device to avoid inaccurate and noisy measurements. The 340i's output sources current and does not use a power supply in series with the output signal. Again, the output of these isolators drives purely resistive loads.

Two-wire Isolators (current repeaters)

So far, we have only discussed isolators that output current to a resistive load. Suppose your application requires an isolator that has a power supply in series with the output signal. This prohibits the use of a 611T, 340i, or 430i isolator. In this case, we must use a two-wire transmitter with input isolation! Acromag's 651T and 250T are two-wire, 4-20mA input transmitters with isolation and can therefore be considered isolators. They are also referred to as a current repeaters.

Some PLC/DCSs are better equipped to handle two-wire transmitters than other devices. Figure 3 shows a simple connection diagram for the

651T/250T transmitter. Note that the output does not go to a purely resistive load. The 651T/250T obtains power from the output loop. Therefore, the transmitter must control current draw from the power supply in the output loop which is the 4-20mA signal. Since output and power share the same two wires, these modules can be placed anywhere between the field sensing device and the PLC/DCS or monitoring device. A typical configuration is to place the transmitter close to the field device. Since both the input and output signal are 4-20mA, location of the device is not critical.

The 651T and 250T are also ideal as current repeaters. Certain monitoring applications require tapping off an existing 4-20mA loop to add a measuring or monitoring instrument. This transmitter is ideal for this application because of the low (10 ohm) input burden. If the isolator fails or loses power, it will not interfere with the existing 4-20mA loop. The output of the transmitter/isolator in this application can be wired to a field chart recorder or another PLC to enable redundant monitoring.

Figure 2:
Isolator receives power from PLC/DCS.
Input isolation required.

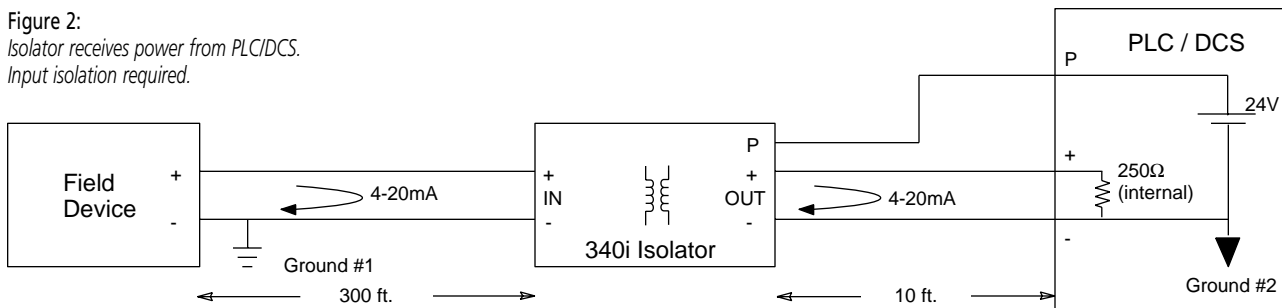
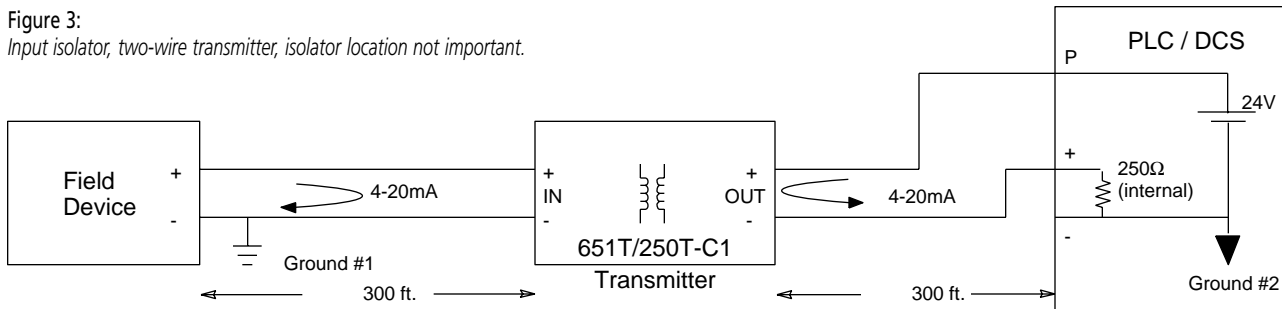

Figure 3:
Input isolator, two-wire transmitter, isolator location not important.





Loop-Powered "Output" Isolators

All the isolators mentioned previously have an input burden of 75 ohm or less. Input burden is the load the isolator places on the 4-20mA current loop it is monitoring. Another type of isolator is the "loop-powered" isolator. This unit is useful when adding and isolating a monitoring instrument to an existing current loop. In Figure 4, field device #2 is added to the existing loop using a 671T or 270i isolator. Note that no additional power source is required for the added loop or for the 671T/270i. The isolator's output is powered by the input loop power and only drives passive loads!

A drawback of "loop-powered" isolators is the burden induced to the initial loop. For example, the 270i's input burden is based on the following equation where R_{LOAD} represents the output load on the 270i:

$$\text{If } R_{LOAD} = 0 \text{ to } 50 \text{ ohms:} \\ V_{BURDEN} = 5.4V + [.0216(R_{LOAD} + 50)]$$

$$\text{If } R_{LOAD} = 50 \text{ to } 600 \text{ ohms:} \\ V_{BURDEN} = 5.4V + [.0216 \times R_{LOAD}]$$

For a 50 ohm load, the input burden is 6.48V using the second equation and 10.8V for a 250 ohm load. The sum of the input voltage burdens must remain below the loop power supply capability at full current. The voltage drops at 20mA in Figure 4 are calculated as follows:

$$V_{BURDEN} = 12V_{(Device \#1)} + 6.48V_{(270i + Device \#2)} \\ + 5V_{(PLC \text{ } 250 \text{ ohms})}$$

$$V_{BURDEN} = 23.5V$$

The PLC power supply could have been used in Figure 4, however if the 4-20mA input is increased to 26mA, the voltage burden will also increase, and the loop will fail due to voltage compliance problems. A 28V power supply will prevent this from occurring since at 26mA the voltage burden is 25.2V DC. Note that an open circuit in the output of the 671T or 270i disrupts the initial loop operation due to increased voltage burden. The 671T/270i can also be used as an output isolator for PLC/DCS 4-20mA outputs. Again, the voltage burden cannot exceed the voltage capability of the PLC/DCS output device.

Improper isolation techniques and model selection account for a large percentage of monitoring and control problems. Acromag isolators offer a reliable, cost-effective solution for a wide variety of applications. If you need technical assistance, please call our application engineers for consultation.

Figure 4:

*Loop-powered isolator.
Output isolation.*

